



ELSEVIER

Available online at www.sciencedirect.com

Molecular Phylogenetics and Evolution 45 (2007) 904–914

MOLECULAR
PHYLOGENETICS
AND
EVOLUTION

www.elsevier.com/locate/ympev

Relationships of *Afroablepharus* Greer, 1974 skinks from the Gulf of Guinea islands based on mitochondrial and nuclear DNA: Patterns of colonization and comments on taxonomy

José Jesus^{a,*}, D. James Harris^b, António Brehm^a^a University of Madeira, Department of Biology, Campus da Penteada, 9000-390 Funchal, Portugal^b Centro de Investigação em Biodiversidade e Recursos Genéticos (CIBIO/UP), Campus Agrário de Vairão, 4485-661 Vairão, Portugal

Received 5 February 2007; revised 17 July 2007; accepted 18 August 2007

Available online 31 August 2007

Abstract

Partial sequences of three mitochondrial DNA genes, 12S rDNA, 16S rDNA and cytochrome *b*, and one nuclear gene, *c-mos*, were used to assess the phylogenetic relationships of species belonging to the genus *Afroablepharus* from the volcanic islands of the Gulf of Guinea (West Africa) and neighboring continental Africa. Additionally, partial sequences of cytochrome *b* were used to compare levels of sequence divergence within populations. The three forms from São Tomé, Príncipe and Annobon (one per island) are genetically distinct, with high levels of divergence, supporting the recognition of a distinct species in each island. Populations within each island contain very low levels of genetic diversity. These three forms form a monophyletic group suggesting a single initial colonization followed by radiation to the other islands, possibly from São Tomé to Príncipe and Annobon. This is contrary to what was found in other reptiles from these islands such as *Mabuya* (sensu lato) and *Hemidactylus*, which colonized the islands multiple times. Assuming a molecular clock for cytochrome *b* of about 2% divergence per million years (usually applied to Sauria), the lineage on Annobon island exceeds the age of the island, thus casting further doubt on this widely used divergence estimate.

Partial sequences of *c-mos* showed no variation within islands. Five to seven sites were variable among islands, which is a high value further supporting the treatment of each island form as a distinct species.

© 2007 Elsevier Inc. All rights reserved.

Keywords: 12S rDNA; 16S rDNA; Cytochrome *b*; *C-mos*; *Panaspis*; *Afroablepharus*; Gulf of Guinea; São Tomé; Príncipe; Annobon

1. Introduction

The forests of West Africa, including the islands of the Gulf of Guinea (Fig. 1) form one of the world's biodiversity hotspots (Myers et al., 2000; Measey et al., 2007). These islands are on a straight axis and part (oceanic sector) of the Cameroon Volcanic Line, which is a flaw or hot-line (Meyers et al., 1998) in the African tectonic plate, about 1500 km long (Simkin and Siebert, 1994; Burke, 2001). Bioko is the largest and closest island to the main-

land, about 32 km from Cameroon and formerly connected to the mainland. The other three islands are smaller and were never connected to the mainland or to each other.

Príncipe is about 220 km southwest from Bioko and 146 km northeast of São Tomé. Annobon is situated about 180 km southwest from São Tomé. Príncipe (128 km²) is at least 31 Myr old, and São Tomé (836 km²) is at least 13 Myr old (Lee et al., 1994). The youngest and smallest of the Gulf of Guinea islands (17 km²) is Annobon with an estimated age of 4.9 Myr old (Lee et al., 1994). This isolation has promoted species divergence, and the islands currently harbor several endemic species including amphibians (Measey et al., 2007), *Hemidactylus* geckos (Jesus et al., 2003, 2005a), *Lygodactylus* geckos (Jesus et al.,

* Corresponding author. Fax: +351 291 705399.

E-mail address: jesus@uma.pt (J. Jesus).

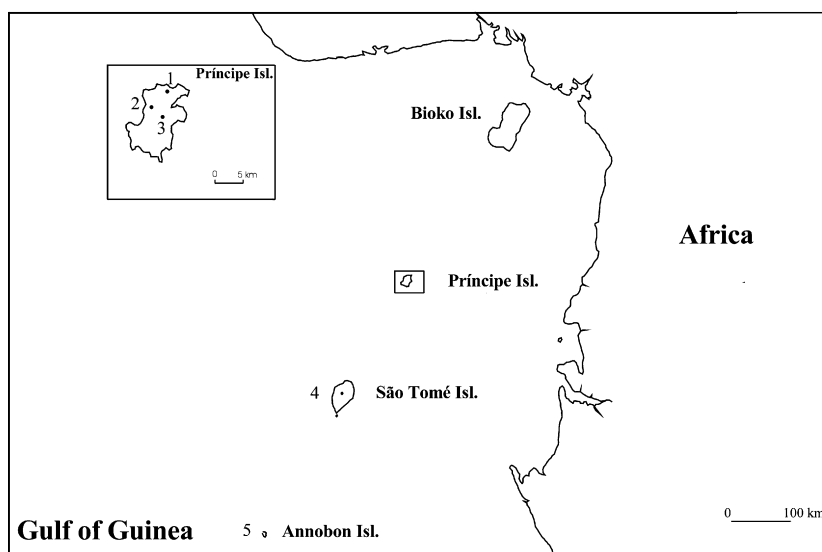

Fig. 1. Map showing sampling localities of *Afroablepharus* spp. from Gulf of Guinea islands sampled in this study. Numbers are as follows: 1. Príncipe—Ponta do Sol, 2. Príncipe—Montalegre, 3. Príncipe—Terreiro Velho, 4. São Tomé—Vale do Contador, 5. Annobon.

2006) *Mabuya* (sensu lato) skinks (Jesus et al., 2003, 2005b, 2005c), and skinks currently assigned to the genus *Afroablepharus*.

The genus *Panaspis* has undergone substantial systematic rearrangement since its creation by Cope in 1868 (see for example, Boulenger, 1887; Smith, 1937; Mittleman, 1952; Fuhn, 1969, 1972; Perret, 1973, 1975; Welch, 1982). Based on morphological characters, Greer, 1974 suggested a new genus, *Afroablepharus* for the species with an ablepharine eye and the contact between the frontal scale and just one subocular scale. The other species, without ablepharine eye, including *P. cabindae*, were included in the genus *Panaspis*.

Molecular data (partial sequences of 12S rDNA and 16S rDNA) was recently used by Schmitz et al., 2005 in a revision of the genus *Panaspis* sensu lato. These authors found considerable genetic differentiation between the different subgenera, and suggested elevation of four former subgenera (*Panaspis*, *Afroablepharus*, *Leptosiaphos* and *Lacertaspis*) to generic rank. The results of Schmitz et al., 2005 suggest that *Panaspis africana* from Príncipe should be renamed *Afroablepharus africanus*, despite the absence of an ablepharine eye and the contact between the frontal scale and subocular made between the frontal and just one subocular. The closest extant relative of *A. africanus*, known so far, is *A. wahlbergi* (Schmitz et al., 2005), a sub-Saharan species found in West Africa.

Fuhn (1972) judged *Panaspis* skinks from Annobon sufficiently different to be considered a distinct subspecies, *Panaspis africana annobonensis*. His study revealed that this subspecies was distinct from the nominal subspecies in the following morphological characters: higher number of subdigital lamellae of the 4th toe of hind limbs, higher number of subdigital lamellae of the 4th toe of fore limbs, relatively longer limbs, the broader first loreal, darker coloration, presence of a darker subocular band well marked, and the presence of a spotted gular region. Based on Fuhn's

study, Perret, 1973 and Welch (1982) considered the subspecies *P. africana annobonensis* Fuhn, 1972 so distinct that they suggested raising the subspecies to full species rank, *P. annobonensis*.

It has been shown that skinks of the genus *Mabuya* colonized these islands independently from the mainland (Jesus et al., 2005c), unlike the Cape Verde islands where all extant *Mabuya* resulted from a single colonization (Brehm et al., 2001). Also, the island endemic geckos of the genus *Hemidactylus* do not form a monophyletic group, suggesting multiple independent colonization events of the islands, contrary to the geckos of the genus *Lygodactylus*, which apparently colonized these islands only once (Jesus et al., 2006). All of these studies showed extensive variation between forms from the different islands, indicating extensive cryptic variation.

Our main objectives were to study the relationships of the *Afroablepharus* spp. from São Tomé, Príncipe and Annobon islands, to assess the colonization patterns of these islands, and to examine levels of variation among the island lineages. This should help to identify cryptic variation, and to contribute towards understanding how these islands were colonized, and whether a comparable phylogeographic pattern exists across different taxa.

2. Materials and methods

2.1. Sampling and molecular methods

The geographic locations and the numbers of specimens used in this study are given in Table 1 and Fig. 1. All individuals of São Tomé, Príncipe and Annobon islands used in this study are deposited in the reptile collection of the University of Madeira. Total genomic DNA was extracted from small pieces of tail by phenol–chloroform standard protocols (Sambrook et al., 1989). PCR primers used in

Table 1
 Details of material and sequences used in the present study; origin of sequences and samples, specimens code, and GenBank Accession Nos.

Species	Locality	Specimen code	Accession Nos.			
			12S	16S	Cytochrome <i>b</i>	<i>C-mos</i>
<i>Afroablepharus africanus</i>	Terreiro Velho, Príncipe, Gulf of Guinea	Pt1	EU164427	EU164462	EU164505	
<i>Afroablepharus africanus</i>	Terreiro Velho, Príncipe, Gulf of Guinea	Pt2	EU164428	EU164463	EU164506	
<i>Afroablepharus africanus</i>	Terreiro Velho, Príncipe, Gulf of Guinea	Pt3	EU164429	EU164464	EU164507	
<i>Afroablepharus africanus</i>	Terreiro Velho, Príncipe, Gulf of Guinea	Pt4	EU164430	EU164465	EU164508	
<i>Afroablepharus africanus</i>	Terreiro Velho, Príncipe, Gulf of Guinea	Pt5	EU164431	EU164466	EU164509	EU164500
<i>Afroablepharus africanus</i>	Terreiro Velho, Príncipe, Gulf of Guinea	Pt6	EU164432	EU164467	EU164510	
<i>Afroablepharus africanus</i>	Terreiro Velho, Príncipe, Gulf of Guinea	Pt7	EU164433	EU164468	EU164511	
<i>Afroablepharus africanus</i>	Ponta do Sol, Príncipe, Gulf of Guinea	Pp1	EU164434	EU164469	EU164512	
<i>Afroablepharus africanus</i>	Ponta do Sol, Príncipe, Gulf of Guinea	Pp2	EU164435	EU164470	EU164513	
<i>Afroablepharus africanus</i>	Ponta do Sol, Príncipe, Gulf of Guinea	Pp3	EU164436	EU164471	EU164514	
<i>Afroablepharus africanus</i>	Ponta do Sol, Príncipe, Gulf of Guinea	Pp4	EU164437	EU164472	EU164515	
<i>Afroablepharus africanus</i>	Ponta do Sol, Príncipe, Gulf of Guinea	Pp5	EU164438	EU164473	EU164516	
<i>Afroablepharus africanus</i>	Ponta do Sol, Príncipe, Gulf of Guinea	Pp6	EU164439	EU164474	EU164517	EU164499
<i>Afroablepharus africanus</i>	Montalegre, Príncipe, Gulf of Guinea	Pm1	EU164440	EU164475	EU164518	EU164501
<i>Afroablepharus africanus</i>	Montalegre, Príncipe, Gulf of Guinea	Pm2	EU164441	EU164476	EU164519	
<i>Afroablepharus africanus</i>	Montalegre, Príncipe, Gulf of Guinea	Pm3	EU164442	EU164477	EU164520	
<i>Afroablepharus sp.</i>	Vale do Contador, São Tomé, Gulf of Guinea	Sv1	EU164443	EU164478	EU164521	EU164502
<i>Afroablepharus sp.</i>	Vale do Contador, São Tomé, Gulf of Guinea	Sv2	EU164444	EU164479	EU164522	EU164503
<i>Afroablepharus annobonensis</i>	Annobon, Gulf of Guinea	An1	EU164445	EU164480	EU164523	
<i>Afroablepharus annobonensis</i>	Annobon, Gulf of Guinea	An2	EU164446	EU164481	EU164524	
<i>Afroablepharus annobonensis</i>	Annobon, Gulf of Guinea	An3	EU164447	EU164482	EU164525	
<i>Afroablepharus annobonensis</i>	Annobon, Gulf of Guinea	An4	EU164448	EU164483	EU164526	
<i>Afroablepharus annobonensis</i>	Annobon, Gulf of Guinea	An5	EU164449	EU164484	EU164527	
<i>Afroablepharus annobonensis</i>	Annobon, Gulf of Guinea	An6	EU164450	EU164485	EU164528	
<i>Afroablepharus annobonensis</i>	Annobon, Gulf of Guinea	An7	EU164451	EU164486		
<i>Afroablepharus annobonensis</i>	Annobon, Gulf of Guinea	An8	EU164452	EU164487	EU164529	
<i>Afroablepharus annobonensis</i>	Annobon, Gulf of Guinea	An9	EU164453	EU164488	EU164530	
<i>Afroablepharus annobonensis</i>	Annobon, Gulf of Guinea	An10	EU164454	EU164489		
<i>Afroablepharus annobonensis</i>	Annobon, Gulf of Guinea	An11	EU164455	EU164490	EU164531	
<i>Afroablepharus annobonensis</i>	Annobon, Gulf of Guinea	An12	EU164456	EU164491	EU164532	
<i>Afroablepharus annobonensis</i>	Annobon, Gulf of Guinea	An13	EU164457	EU164492	EU164533	
<i>Afroablepharus annobonensis</i>	Annobon, Gulf of Guinea	An14	EU164458	EU164493	EU164534	EU164498
<i>Afroablepharus annobonensis</i>	Annobon, Gulf of Guinea	An15	EU164459	EU164494	EU164535	EU164497
<i>Afroablepharus africanus</i>	Príncipe, Gulf of Guinea	BMNH, uncatalogued	AY308438	AY308286		
<i>Afroablepharus wahlbergi</i>	Pilgrims Rest, South Africa	ZFMK 77818	AY308327	AY308178		
<i>Panaspis togoensis</i>	Benakuma, West of Wum, Cameroon	MNHM 2001.0699	AY308441	AY308290		
<i>Panaspis breviceps</i> I	Mt. Kupe, Cameroon	Voucher not collected	AY308439	AY308287		
<i>Panaspis breviceps</i> II	Mt. Nlonako, Cameroon	ZFMK 75380	AY308440	AY308288		
<i>Lacertaspis gemmiventris</i>	Ekona Lulu, Mt. Cameroon, Cameroon	MNHN 2002.0024	AY308383	AY308233		
<i>Lacertaspis gemmiventris</i> I	Bioko Id.: vic Moka Malabo, Equatorial Guinea	CAS 207861	AY308376	AY308227		
<i>Lacertaspis gemmiventris</i> II	Bioko Id.: vic Moka Malabo, Equatorial Guinea	CAS 207860	AY308377	AY308228		
<i>Lacertaspis gemmiventris</i> III	Bioko Id.: vic Moka Malabo, Equatorial Guinea	CAS 207858	AY308378	AY308229		
<i>Lacertaspis gemmiventris</i> IV	Bioko Id.: vic Moka Malabo, Equatorial Guinea	CAS 207854	AY308379	AY308230		
<i>Lacertaspis gemmiventris</i> V	Bioko Id.: vic Moka Malabo, Equatorial Guinea	CAS 207857	AY308381	AY308231		
<i>Lacertaspis gemmiventris</i> VI	Bioko Id.: vic Moka Malabo, Equatorial Guinea	CAS 207 855	AY308382	AY308232		
<i>Lacertaspis lepesmei</i>	Bamboutos, “House of the Fulbe”, Cameroon	MNHN 2004.0061	AY308384	AY308234		
<i>Lacertaspis chriswildi</i>	Tchabal Mbabo, Cameroon	ZFMK 75735	AY308375	AY308226		
<i>Lacertaspis rhodei</i> I	Mt. Nlonako, Cameroon	ZFMK 75382	AY308386	AY308236		
<i>Lacertaspis rhodei</i> II	Nzobi, Banyang-Mbo, Mt. Cameroon, Cameroon	MNHN 2002.0797	AY308387	AY308237		

Table 1 (continued)

Species	Locality	Specimen code	Accession Nos.			
			12S	16S	Cytochrome <i>b</i>	<i>C-mos</i>
<i>Lacertaspis rhodei</i> III	Limbo, Banyang-Mbo, Mt. Cameroon, Cameroon	MNHN 2002.0796	AY308388	AY308238		
<i>Lacertaspis reichenowi</i>	Mt. Nlonako, Cameroon	ZFMK 68965	AY308385	AY308235		
<i>Leptosiaphos</i> sp. I	Mt. Nlonako, Cameroon	ZFMK 69551	AY308401	AY308251		
<i>Leptosiaphos</i> sp. II	Mt. Nlonako, Cameroon	ZFMK 68291	AY308402	AY308252		
<i>Leptosiaphos</i> sp. III	Mt. Nlonako, Cameroon	ZFMK 69554	AY308403	AY308253		
<i>Leptosiaphos</i> sp. IV	Mt. Nlonako, Cameroon	Voucher not collected	AY308408	AY308254		
<i>Leptosiaphos</i> sp. V	Mt. Nlonako, Cameroon	ZFMK 75381	AY308407	AY308255		
<i>Leptosiaphos</i> sp. VI	Bioko Id.: vic Moka Malabo, Equatorial Guinea	CAS 207864	AY308405	AY308256		
<i>Leptosiaphos</i> sp. VII	Bioko Id.: vic Moka Malabo, Equatorial Guinea	CAS207865	AY308406	AY308257		
<i>Leptosiaphos amieti</i>	Mt. Nlonako, Cameroon	ZFMK 69530	AY308392	AY308242		
<i>Leptosiaphos vigintiserierum</i> I	Mt. Nlonako, Cameroon	ZFMK 69429	AY308410	AY308258		EU164504
<i>Leptosiaphos vigintiserierum</i> II	Mt. Cameroon, Cameroon	MNHN 2004.0062	AY308409	AY308259		
<i>Leptosiaphos kilimensis</i> I	Usambara: Kwamkoro, Tanzania	ZFMK 77815	AY308399	AY308249		
<i>Leptosiaphos kilimensis</i> II	Usambara: Amani, Tanzania	ZFMK 77816	AY308398	AY308248		
<i>Leptosiaphos kilimensis</i> III	Ke, Chuka, Kenya	ZFMK 77817	AY308393	AY308243		
<i>Leptosiaphos koutoui</i>	Meiganga, Cameroon	MNHN 2001.0697	AY308400	AY308250		
<i>Leptosiaphos graueri</i> I	Bwindi Impenetrable NP, Uganda	CAS 201705	AY308396	AY308244		
<i>Leptosiaphos graueri</i> II	Kabale-Kayonza, Bwindi Impenetrable NP, Uganda	CAS 201776	AY308394	AY308245		
<i>Leptosiaphos graueri quinquedigitata</i>	Gakarara, Rwanda	ZFMK 55877	AY308395	AY308246		
<i>Leiopisma telfarii</i>			AF280122	AY151450		
<i>Chalcides chalcides</i>			AJ416936	AJ416935		
<i>Mabuya maculilabris</i>	Rolas islet, São Tomé, Gulf of Guinea	562	EU164460	EU164496	AY997748	
<i>Mabuya vaillanti</i>						AF335088
<i>Mabuya fogoensis</i>						AF335082
<i>Feylinia polylepis</i>	Terreiro Velho, Príncipe, Gulf of Guinea	579	EU164461	EU164495	EU164536	

Species names are according to suggestions and results reported by Schmitz et al. (2005). Taxon designation for Annobon, *Afroablepharus annobonensis*, is according to suggestions made by Perret (1973). Codes refer to voucher specimens. Except for *Afroablepharus* spp. from Annobon, São Tomé and Príncipe islands, and *Mabuya maculilabris*, *Feylinia polylepis* and *Leptosiaphos vigintiserierum* (only for *C-mos*), the source of information was GenBank. Data about localities and voucher names of the sequences from GenBank were provided by Andreas Schmitz (*pers. comm.*).

both amplification and sequencing were 12Sa and 12Sb (Kocher et al., 1989), 16SL and 16SH (Simon et al., 1990), cytB1 and CB3H (Palumbi et al., 1991), and G73 and G74 for a fragment of the nuclear gene, *c-mos* (Saint et al., 1998). Two other primers were used for sequencing the cytochrome *b* gene: cytochrome *b2* from Kocher et al. (1989) and P1 (in this study, 5'-TGA GGA CAA ATA TCA TTY TGR GG-3'). The PCR cycling procedure was as follows. For 12S rDNA, an initial denaturation step: 4 min at 94 °C; 35 cycles: denaturation 30 s at 94 °C, primer annealing for 30 s at 50 °C; extension for 30 s at 72 °C; and a final step of 5 min at 72 °C. For 16S rDNA, an initial denaturation step: 5 min at 85 °C; 35 cycles: denaturation 35 s at 94 °C, primer annealing for 3 s at 50 °C; extension for 1 min at 72 °C; and a final step of 5 min at 72 °C. For cytochrome *b*, an initial denaturation step: 5 min at 85 °C; 35 cycles: denaturation 40 s at 94 °C, primer annealing for 50 s at 50 °C; extension for 2 min 72 °C; and a final step of 5 min at 72 °C. For *c-mos*, an initial denaturation step: 3 min at 94 °C; 40 cycles: denaturation 25 s at 94 °C, primer annealing for 55 s at 50 °C;

extension for 40 s at 70 °C; and a final step of 3 min at 72 °C. PCR fragments were sequenced in a ABI 310 sequencer (Applied Biosystem DNA Sequencing Apparatus).

DNA sequences were aligned using Clustal W (Thompson et al., 1994). Two data sets were considered, one with combined aligned 12S rDNA and 16S rDNA sequences of about 366 bp and 417 bp, respectively, and another with combined aligned 12S rDNA, 16S rDNA and cytochrome *b* of about 366 bp, 417 bp and 640 bp, respectively. The first dataset included more outgroups because more were available in GenBank for these two genes. The second included fewer outgroups for the combined gene sequences. Cytochrome *b* revealed no indels. These two datasets were used to estimate the phylogenetic relationships among *taxa*. Only cytochrome *b* (about 640 bp long) was used to estimate the genetic distances and divergence times of samples from São Tomé, Príncipe and Annobon. Because phylogenetic reconstruction is based on positional homologies, the regions that could not be unambiguously aligned due to extensive length variations were excluded from further

analysis (50 bp from 16S rDNA). The alignment is available on request from the corresponding author. We sequenced the 12S rDNA and 16S rDNA fragments in 33 *Afroablepharus*, and for cytochrome *b* we sequenced 31 *Afroablepharus* samples from the Gulf of Guinea islands (see Table 1). For 12S rDNA and 16S rDNA we compared this, for phylogenetic analysis, to 35 overlapping partial sequences of 12S rDNA and 16S rDNA of mainland *Panaspis* (sensu lato; Schmitz et al., 2005), that were fully overlapping with our 783 bp sequences. We also included in this analysis the partial sequences of these two genes from several outgroups: one individual of *Mabuya maculilabris* from São Tomé (Rolas islets, voucher #562, Jesus et al., 2005b), one *Chalcides chalcides* (GenBank Accession No., AJ416936, for 12S rDNA, and AJ416935 for 16S rDNA) and one *Leiopisma telfairii* (GenBank Accession No., AF280122, for 12S rDNA, and AY151450 for 16S rDNA) (Table 1). For the combined dataset of 12S rDNA, 16S rDNA and cytochrome *b* we used sequences from 31 individuals and, for phylogenetic analysis, we added two outgroups, *Mabuya maculilabris* and *Feylinia polylepis* (see Table 1). For *c-mos* we sequenced 31 individuals (2 from São Tomé, 14 from Annobon and 14 from Príncipe) resulting in a fragment of 331 bp. No intra-island variation was found, so we just used for further phylogenetic analysis 2 sequences from São Tomé (Sv1 and Sv2), 3 from Príncipe (Pp6, Pt5 and Pm1), and 2 from Annobon (An14 and An15). *C-mos* data were included as an independent nuclear marker. We also analysed *c-mos* sequences from *Leptosiaphos vigitiserierum*, *Mabuya vaillanti* (#AF335088) and one *Mabuya fogoensis* (#AF335082) as outgroups.

2.2. Data analysis

True evolutionary relationships may be obscured in DNA sequence data sets if sites have become saturated by multiple substitutions (Swofford et al., 1996). To test for saturation, observed pairwise proportions of transitions and transversions in the separate 12S rDNA, 16S rDNA and cytochrome *b* were plotted against sequence divergence and calculated using DAMBE version 4.2.13 (Xia and Xie, 2001).

Differences in substitution rates between gene regions can potentially produce conflicting signals if one gene is saturated. Thus, before proceeding with the analysis, a partition-homogeneity test was applied to data (Farris et al., 1994) implemented in PAUP* 4.0b10 (Swofford, 2002) to evaluate whether the two or three gene regions contained significantly different phylogenetic signals. This test indicated no significant incongruence between regions ($p = 0.68$ (matrix of 2 genes), $p = 0.96$ (matrix containing the three genes)), so they were combined in the phylogenetic analysis.

The data were imported to PAUP* 4.0b10 (Swofford, 2002) and to MEGA version 3.1 (Kumar et al., 2004) for phylogenetic analysis. For the phylogenetic analysis we

used maximum likelihood (ML) and Bayesian inference. We followed the approach outlined by Huelsenbeck and Crandall (1997) to test 56 alternative models of evolution, employing PAUP* 4.0b10 and Modeltest 3.7 (Posada and Crandall, 1998). Once a model of evolution was chosen according to Akaike information criterion following Posada and Buckley (2004), it was used to estimate a tree using ML criteria (Felsenstein, 1985). An heuristic search with tree bisection reconnection (TBR) and 10 replicates of random addition of taxa was performed to estimate a tree. Steepest descent option was not in effect, and the MULPARS option was used. The relative robustness of each dichotomy was established by bootstrap analysis. Non-parametric bootstrap support for nodes was estimated using the “fast” option with 100 heuristic bootstrap replicates implemented in PAUP* 4.0b10. The Bayesian analysis was implemented using MrBayes v3.1.2 (Huelsenbeck and Ronquist, 2001), which calculates Bayesian posterior probabilities using a Metropolis-coupled, Markov chain Monte Carlo (MC-MCMC) analysis. Bayesian analysis was conducted with random starting trees, four MCMC chains (one cold, three heated), run 0.5×10^6 generations, and sampled every 100 generations using a General-Time-Reversible model of evolution with a gamma model of among-site rate variation. Two additional analyses were performed with different numbers of generations, 5×10^6 and 1×10^7 , giving the same results. In all searches stationarity of the Markov Chain was determined as the point when sampled negative log-likelihood values plotted against the number of generations reached a stable mean equilibrium value; “burn-in” data sampled from generations preceding this point were discarded. The burn-in value was 500 for combined 12S rDNA and 16S rDNA dataset and 1000 for combined 12S rDNA, 16S rDNA and cytochrome *b* dataset. Convergence between runs (as measured by effective sample size, ESS) and posterior probabilities of the estimates were determined using the software program Tracer (Rambaut and Drummond, 2005). According to Ho et al. (2005), the effective population size is influenced not only by the number of samples that are drawn from the MCMC but also by the degree of autocorrelation among samples. The preliminary analysis revealed that the burn-in was sufficient. This was confirmed by a posterior analysis of the MCMC samples with program Tracer. All data collected at stationarity were used to estimate posterior nodal probabilities and a summary of phylogeny. These posterior probabilities of each clade were used as a support measure. This analysis was repeated for the two datasets, the combined 12S rDNA and 16S rDNA, and the combined 12S rDNA, 16S rDNA and cytochrome *b*. Because of the very low levels of sequence variation in *c-mos*, a MP analysis was performed for this dataset. The maximum parsimony searches were performed in Mega version 3.1 using close-neighbor interchange with 1000 bootstrap replicates. The starting trees for close-neighbor interchange were selected by random addition with 1000 replicates and a search level of 3.

3. Results

Plots of observed pairwise divergences of haplotypes for transitions and transversions in the separate 12S rDNA, 16S rDNA and cytochrome *b* against total sequence divergence revealed negligible saturation (data not shown), so our analyses included all sites.

The combined 12S and 16S rDNA gene fragments gave a total segment of 783 bp with 245 variable sites of which 197 were parsimony informative. The most appropriate model for the combined data was the GTR model (Rodríguez et al., 1990), with a discrete approximation to a gamma-distributed rate-heterogeneity model ($\alpha = 0.5807$), and an estimate of invariable sites ($I = 0.5284$). An heuristic search incorporating this model found one tree of $-\ln 4617.63$. Bayesian analysis, considering the GTR + I + G model, produced a very similar estimate of relationship as the ML analysis. The main differences were in relationships among haplotypes from the same island. The combined 12S rDNA, 16S rDNA and cytochrome *b* gene fragments gave a total segment of 1416 bp with 419 variable sites of which 282 were parsimony informative. The most appropriate model for the combined data was the GTR model (Rodríguez et al., 1990), with a discrete approximation to a gamma-distributed rate-heterogeneity model ($\alpha = 0.5452$), and an estimate of invariable sites ($I = 0.4002$). An heuristic search incorporating this model found one tree of $-\ln 4749.63$. Bayesian analysis, considering the GTR + I + G model, produced a similar estimate of relationship, again with differences restricted to short nodes connecting haplotypes from the same island.

A similar pattern of relationships was found either using the 12S rDNA + 16S rDNA dataset, or using all mitochondrial data. The use of more characters did not improve the support for relationships. The node that separates the Príncipe from São Tomé samples is better supported in the first dataset (bootstrap value = 97), than the second dataset (bootstrap value = 59). Usually when we increase the length of sequences, the bootstrap values increase. This is not the case, and probably this is due to different outgroups being used in the two datasets; in this situation bootstraps (i.e. support values) cannot be directly compared.

In all analyses, haplotypes from the three islands formed a clade with 100% support. Major clades, particularly those identified by Schmitz et al., 2005 are also well supported with 99–100% support (Figs. 2 and 3).

Also well supported is the relationship between the group of forms from São Tomé, Príncipe and Annobon, and the sister-taxon *A. wahlbergi*, as well as the relationship between this group (*Afroablepharus* spp.) and the its sister-taxon *Panaspis* spp. (Fig. 2).

Levels of sequence divergence between congeneric reptile species is known to average approximately 12% for cytochrome *b* (Harris, 2002). Sequence divergence for cytochrome *b* between populations from Annobon and Príncipe is approximately 21%, between Annobon and São Tomé 22%, and between Príncipe and São Tomé divergence is

approximately 23% (Tables 2 and 3). The minimum value obtained was between an individual of Príncipe and an individual of Annobon (0.203). Intra-island cytochrome *b* divergences are substantially lower than inter-island divergences (Table 3).

The *c-mos* sequences revealed no variation within populations. However between Annobon and Príncipe the sequences differed in five sites, between Annobon and São Tomé in 7, and between São Tomé and Príncipe in six sites. These values were much higher than those observed between *Mabuya vaillanti* (#AF335088) and *Mabuya fogoensis* #AF335082 (only 3), distinct species from the Cape Verde islands. These results are in agreement with mtDNA data and support the hypothesis that the high divergences found in the cytochrome *b* data are not an artefact, but represent overall high divergences between island forms. These values are also higher than those found in *Lygodactylus* from these islands (Jesus et al., 2006). The MP tree shows that a clear differentiation exists between the three island forms of Gulf of Guinea (Fig. 4). No heterozygotes were found, and only three haplotypes, one per island, were found in these islands. The three forms were also clearly differentiated from the other species included in the analysis. Both nuclear and mitochondrial DNA sequences gave the same results with the recognition of a clade formed by Príncipe and São Tomé, although with high divergence between samples of these two islands. In both analyses the Príncipe + São Tomé and Annobon appear as sister clades (Figs. 2–4).

4. Discussion

4.1. Patterns of colonization in the islands of Gulf of Guinea

Analysis of 12S rDNA, 16S rDNA and cytochrome *b* sequences produced robust estimates of relationships for the populations from the three islands. From our analyses we can state: (i) the results suggest monophyly of Gulf of Guinea species, and thus indicate a single initial colonization event followed by radiation to the other islands; (ii) the ancestor of the three forms dispersed to the islands from Western Africa (perhaps within the current range of *Afroablepharus wahlbergi*). The closest related mainland *Afroablepharus* (*A. wahlbergi*) is distributed in eastern and western Africa from South Africa to Democratic Republic of Congo.

When a single colonization event occurs in an archipelago, the simplest model of inter-island colonization is that of stepping stone colonization. However sometimes the topology of the tree is not congruent with this simple model. According to Emerson (2002) there are some methods for inference of sequence of colonization. One method uses tree topology and geography under the premise that an island will be colonized by neighboring island rather than a more distant one. The other method infers the direction of colonization using information from tree topology and branch length. This method is based on the assumption

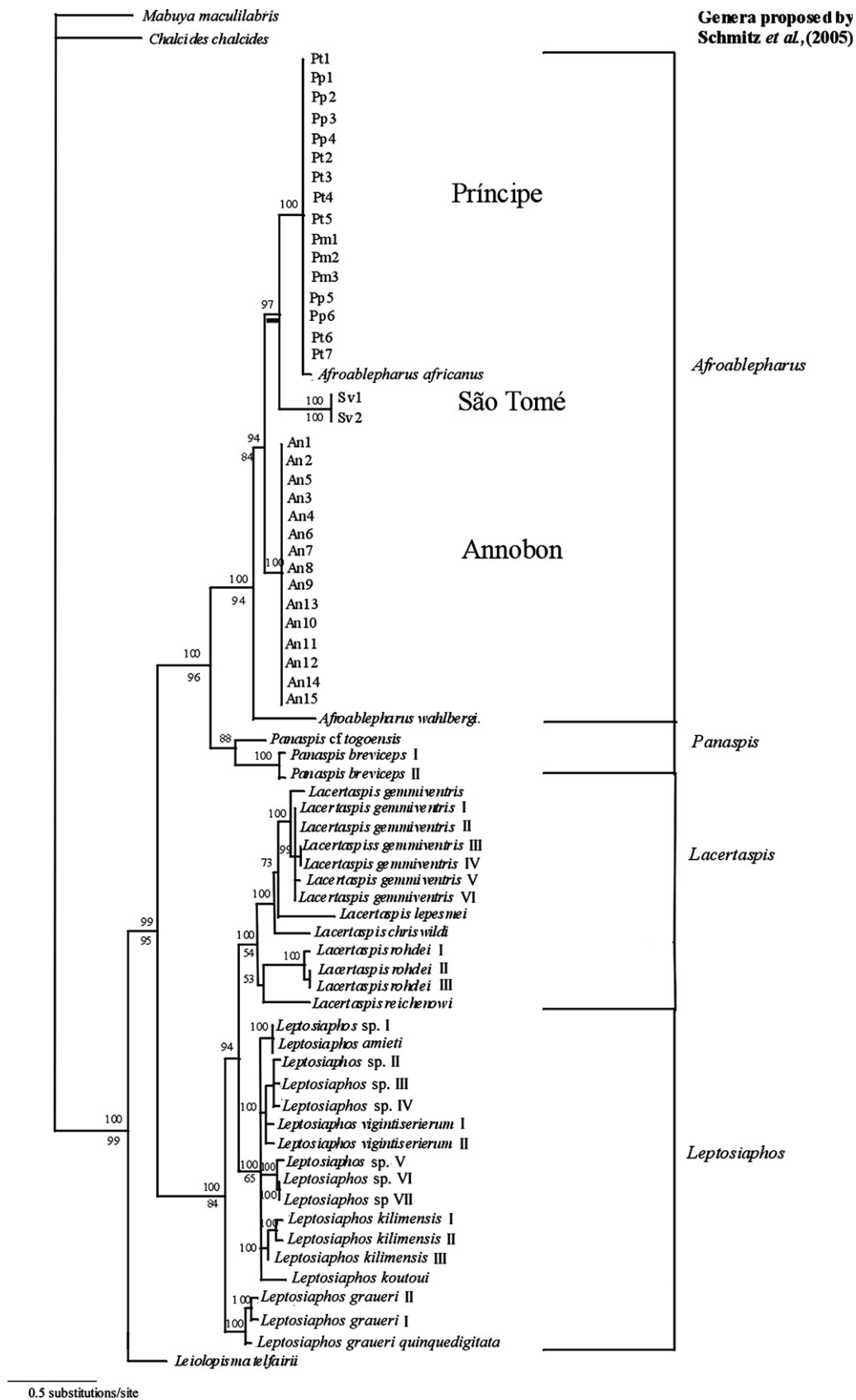

Fig. 2. Tree derived from Bayesian analysis of combined 12S and 16S rDNA fragments. Average posterior probabilities are shown above nodes. The tree was rooted using *Mabuya maculilabris* and *Chalcides chalcides*. The tree derived from ML analysis, obtained with PAUP and with a model of sequence evolution GTR + I + G (described in the text), shows a similar pattern, except for being less well resolved and few differences in terminal branches on small groups (bootstrap values are shown below the nodes, but only for the major groups).

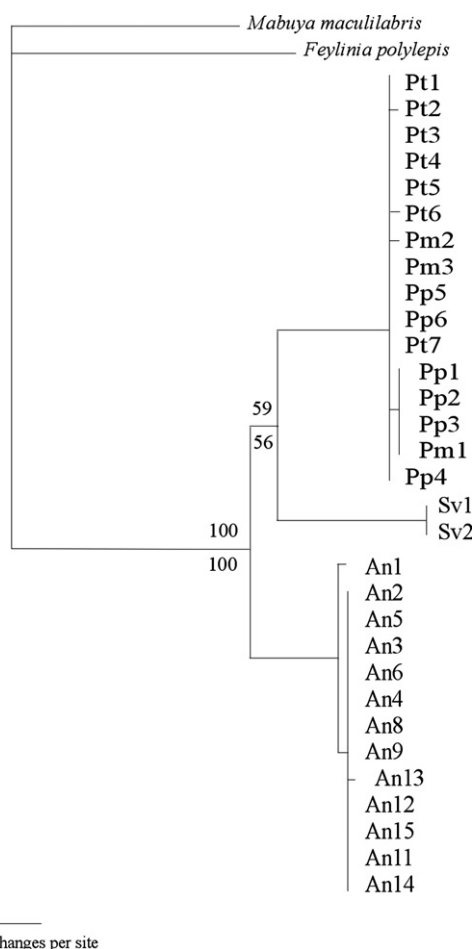

Fig. 3. Tree derived from Bayesian analysis of combined 12S rDNA, 16S rDNA fragments and cytochrome *b*. Average posterior probabilities are shown above nodes. The tree was rooted using *Mabuya maculilabris* and *Feylinia polylepis*. The tree derived from ML analysis, obtained with PAUP and with a model of sequence evolution GTR + I + G (described in the text), shows a similar pattern. Bootstrap values are shown below the nodes, but only for the major groups.

that there is a rapid molecular divergence caused by a founding event. So, taking into account the greater branch lengths and longer distances of Annobon to the continent,

Table 2
Cytochrome *b* K2P pairwise distances for the island *Afroablepharus* haplotypes used in this study

	Pt1	Pt6	Pt7	Pp5	Pp6	Pm1	Pm2	Pm3	Sv1	Sv2	An1	An2
Pt6	0.005											
Pt7	0.000	0.005										
Pp5	0.002	0.007	0.002									
Pp6	0.000	0.005	0.000	0.002								
Pm1	0.017	0.022	0.017	0.019	0.017							
Pm2	0.002	0.002	0.002	0.005	0.002	0.019						
Pm3	0.000	0.005	0.000	0.002	0.000	0.017	0.002					
Sv1	0.231	0.237	0.231	0.231	0.231	0.245	0.234	0.231				
Sv2	0.231	0.237	0.231	0.231	0.231	0.245	0.234	0.231	0.005			
An1	0.207	0.213	0.207	0.203	0.207	0.213	0.210	0.207	0.222	0.222		
An2	0.213	0.220	0.213	0.210	0.213	0.220	0.216	0.213	0.219	0.219	0.007	
An3	0.213	0.220	0.213	0.210	0.213	0.220	0.216	0.213	0.219	0.219	0.009	0.002

Coding/abbreviations are as follows: An. Annobon, Pt. Príncipe—Terreiro Velho, Pm. Príncipe—Montalegre, Pp. Príncipe—Ponta do Sol, Sv. São Tomé—Vale do Contador. Following the two letters are numbers that identify the samples or each individual.

Table 3
Descriptive statistics of cytochrome *b* K2P pairwise distances among and between islands of *Afroablepharus* haplotypes used in this study

	Príncipe	São Tomé	Annobon
Príncipe	0.00788 ± 0.00609 [0.022; 0]	0.23431 ± 0.00383 [0.245; 0.231]	0.21562 ± 0.00452 [0.223; 0.203]
São Tomé		0.005	0.21831 ± 0.00213 [0.222; 0.216]
Annobon			0.00345 ± 0.00272 [0.009; 0]

In each cell, the upper line gives mean ± standard deviation; the lower line gives the maximum and minimum.

the most parsimonious scenario seems to be that the first island that was colonized was São Tomé, followed by spreading to other islands.

Given the high intraspecific diversity recorded in these islands, more sampling in sub-Saharan Africa is clearly necessary. Indeed, it would be interesting to investigate the genetic diversity of *Afroablepharus*, particularly *A. wahlbergi*, throughout its range. Phylogeographic structuring of *A. wahlbergi* populations may provide some further indication of the most likely geographic origin of the Gulf of Guinea island taxa.

The colonization pattern of *Afroablepharus* does not seem to be similar to other reptiles from these islands. *Mabuya* spp. on the islands do not form a clade, suggesting separate colonization of each island from the mainland (Jesus et al., 2005c). Endemic island geckos of the genus *Hemidactylus* also do not form a monophyletic group and probably colonized the islands from the mainland more than once (Jesus et al., 2005a).

Considering the molecular clock in other reptiles of about 2% divergence per Myr for cytochrome *b* on the lacertid lizard *Gallotia* (Carranza et al., 2000), 2.2% for other lacertid lizards (Maca-Meyer et al., 2003), or even 2.6% per million years in *Tarentola* (Carranza et al., 2002), it is extremely difficult to explain these results. Using the value of 2%, the forms from the three islands split about 10 Myr ago, which is difficult to reconcile with the age of Annobon (4.5 Myr). Either the molecular clock rate does not apply

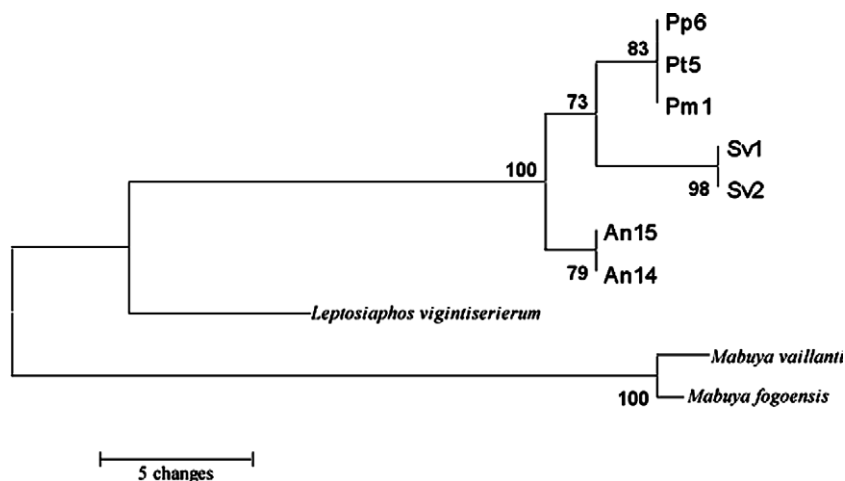

Fig. 4. MP tree obtained with Close-Neighbor-Interchange (CNI) with search level 3, showing the relationships derived from partial sequences of *c-mos*. As all individuals within an island shared the same haplotype, not all are indicated. Coding/abbreviations areas follows: An. Annobon, Pt. Príncipe—Terreiro Velho, Pm. Príncipe—Montalegre, Pp. Príncipe—Ponta do Sol, Sv. São Tomé—Vale do Contador. Following the two letters are numbers that identify the samples or each individual. Bootstrap values are shown above the nodes (see text for more details).

to the *Panaspis* skinks of Gulf of Guinea populations, or the geological dating of the emergence of the islands is erroneous. If the molecular clock is well calibrated, a possible explanation is that the lineage of Annobon originated elsewhere but currently exists only in Annobon. Following this reasoning, the forms in Gulf of Guinea would eventually have different mainland ancestors either unsampled or even extinct. It is almost impossible to sample all probable origin areas, because they are extensive and because some species could be geographically restricted and, as in Gulf of Guinea, living among leaf litter, are difficult to discover. However, this seems unlikely since it would imply the form evolved on one of the other Gulf of Guinea islands in sympatry with another lineage of *Afroablepharus*. Such scenarios rarely occur on small islands where minimal separation into different ecological niches is possible. Further all *Afroablepharus* currently found on the islands occupy the same niche, being found in leaf litter in the forests, and are very similar morphologically. It seems more likely that the currently used calibration is unreliable across different taxa. This has also been reported from *Anolis extremus* of Barbados islands (Thorpe et al., 2005), and clearly deserves further investigation.

4.2. Taxonomic status of the Gulf of Guinea species

Except for São Tomé where only two individuals were studied, the genetic diversity within each island is very low (Table 2 and Fig. 2), probably due to the small population size on islands, to bottlenecks from colonization, or to a strong directional selection. In fact these skinks were found in leaf litter only in moist and shady places, under trees (Jesus et al., 2003; pers. obs).

Our results group Gulf of Guinea populations with *Afroablepharus wahlbergi* (see Fig. 2). So, despite lacking typical morphological features of *Afroablepharus*, the forms from Gulf of Guinea must be considered as *Afroab-*

lepharus. One hypothesis to be tested in the future is that the typical morphological characters used at generic level are homoplastic.

The values for divergence between islands based on cytochrome *b*, are extremely high for intraspecific variation. Values of 20–23% of divergence observed between the three islands are much higher than the average value obtained for other reptiles (Harris, 2002). Also in *c-mos* we found a higher number of differences (5–7) between the forms of Gulf of Guinea than between other recognized species such as *Mabuya vaillanti* and *Mabuya fogoensis* (Brehm et al., 2001).

We recognize three different species. Morphological differences between the forms of Príncipe and São Tomé are practically absent, and this was, probably, the reason why the original description made by Gray, 1845 of *A. africanus* was apparently based on lizards from Príncipe and São Tomé. Unfortunately the type locality is given only as “West Africa”. We suggest that the form from Príncipe should retain the name *A. africanus* and the *Terra typica* should be restricted to Príncipe. The form from São Tomé should be considered a new species, pending ongoing morphological analyses. The process of description of the form of São Tomé is almost done.

Although similar in general morphology the form from Annobon presents some morphological differences, namely higher number of subdigital lamellae in the fourth toe of the hind and fore limbs, relatively longer limbs, broader loreal and darker colour (Fuhn, 1972; Perret, 1973). These differences were sufficient to consider the form of Annobon a different subspecies, *A. africanus annobonensis* (Fuhn, 1972) or even to be suggested as different species (Perret, 1973). The statement of Perret, 1973 is enhanced by our results. The morphological differences, and the high genetic divergence in relation to other forms of Gulf of Guinea, obtained in this study, should be sufficient to consider the form of Annobon a different species, *A. annobonensis*.

Acknowledgments

This project was supported by grants from Fundação para a Ciência e Tecnologia POCTI/41906/BSE/2001 and SFRH/BDP/5702/2001. Fieldwork was also supported by the Instituto Gulbenkian de Ciência (to D.J.H.).

We would like to thank the Government of São Tomé and Príncipe and the Representative of Equatorial Guinea in São Tomé for the permissions to perform the field work.

We would like to thank Andreas Schmitz for providing some data, samples and sequences of *Panaspis* (sensu lato), and Robert Drewes for providing some important references.

We also thank the anonymous referees for their comments.

References

- Boulenger, G.A., 1887. Catalogue of the lizards in the British Museum (Natural History).
- Brehm, A., Jesus, J., Pinheiro, M., Harris, D.J., 2001. Relationships of scincid lizards (*Mabuya* spp.; Reptilia: Scincidae) from Cape Verde islands based on mitochondrial and nuclear DNA sequences. *Mol. Phylogenet. Evol.* 19, 311–416.
- Burke, K., 2001. Origin of the Cameroon line of volcano-capped swells. *J. Geol.* 109, 349–362.
- Carranza, S., Arnold, E.N., Mateo, J.A., Lopez-Jurado, L.F., 2000. Long-distance colonization and radiation in gekkonid lizards, *Tarentola* (Reptilia: Gekkonidae) revealed by mitochondrial DNA sequences. *Proc. R. Soc. Lond. B* 267, 637–649.
- Carranza, S., Arnold, E.N., Mateo, J.A., Geniez, P., 2002. Relationships and evolution of the North African geckos *Geckonia* and *Tarentola*, based on mitochondrial and nuclear DNA sequences. *Mol. Phylogenet. Evol.* 23, 244–256.
- Cope, E.D., 1868. Observations on reptiles of the Old World, II. *Proc. Acad. Nat. Sci. Phila.* 1868, 316–323.
- Emerson, B.C., 2002. Evolution on oceanic islands: molecular phylogenetic approaches to understanding pattern and process. *Mol. Ecol.* 11, 951–966.
- Farris, J.S., Klällersjö, M., Kluge, A.G., Bult, C., 1994. Testing significance of congruence. *Cladistics* 10, 315–319.
- Felsenstein, J., 1985. Confidence limits on phylogenies: an approach using the bootstrap. *Evolution* 39, 783–791.
- Fuhn, I.E., 1969. Revision and redefinition of the genus *Ablepharus* Lichtenstein, 1823 (Reptilia, Scincidae). *Revue roum. Biol. Zool.* 14, 23–41.
- Fuhn, I.E., 1972. Révision du phylum forestier du genre *Panaspis* Cope (Reptilia, Scincidae, Lygosominae). *Revue roum. Biol. Zool.* 17, 257–271.
- Gray, I.E., 1845. Catalogue of the specimens of lizards in the collection of the British Museum, London.
- Greer, A.E., 1974. The generic relationships of the scincid lizard genus *Leiopisma* and its relatives. *Aust. J. Zool., Suppl. Ser.* 31, 1–67.
- Harris, D.J., 2002. Reassessment of comparative genetic distance in reptiles from the mitochondrial *cytochrome b* gene. *Herp. J.* 12, 85–86.
- Ho, S.Y.W., Phillips, M.J., Drummond, A.J., Cooper, A., 2005. Accuracy of rate estimation using relaxed-clock models with a critical focus on the early metazoan radiation. *Mol. Biol. Evol.* 22, 1355–1363.
- Huelsenbeck, J.P., Crandall, K.A., 1997. Phylogeny estimation and hypothesis testing using maximum likelihood. *Ann. Rev. Ecol. Syst.* 28, 437–466.
- Huelsenbeck, J.P., Ronquist, F., 2001. MR-BAYES: Bayesian inference of phylogeny. *Bioinformatics* 17, 754–755.
- Jesus, J., Brehm, A., Harris, D.J., 2003. The herpetofauna of Annobon island, Gulf of Guinea, West Africa. *Br. Herp. Soc. Bull.* 86, 20–22.
- Jesus, J., Brehm, A., Harris, D.J., 2005a. Phylogenetic relationships of *Hemidactylus* geckos from the Gulf of Guinea islands: patterns of natural colonizations and anthropogenic introductions estimated from mitochondrial and nuclear DNA sequences. *Mol. Phylogenet. Evol.* 37, 480–485.
- Jesus, J., Harris, D.J., Brehm, A., 2005b. Phylogeography of *Mabuya maculilabris* (Reptilia) from São Tomé Island (Gulf of Guinea) inferred from mtDNA sequences. *Mol. Phylogenet. Evol.* 37, 503–510.
- Jesus, J., Brehm, A., Harris, D.J., 2005c. Relationships of scincid lizards (*Mabuya* spp.) from the islands of the Gulf of Guinea based on mtDNA sequence data. *Amphibia-Reptilia* 26, 467–473.
- Jesus, J., Brehm, A., Harris, D.J., 2006. Phylogenetic relationships of *Lygodactylus* geckos from the Gulf of Guinea islands: rapid rates of mitochondrial DNA sequence evolution?. *Herpetol. J.* 16, 291–295.
- Kocher, T.D., Thomas, W.K., Meyer, A., Edwards, S.V., Pääbo, S., Villablanca, F.X., Wilson, A.C., 1989. Dynamics of mitochondrial DNA evolution in animals: amplification and sequencing with conserved primers. *Proc. Natl. Acad. Sci. USA* 86, 6196–6200.
- Kumar, S., Tamura, K., Nei, M., 2004. MEGA3: integrated software for molecular evolutionary genetics analysis and sequence alignment. *Brief. Bioinform.* 5, 150–163.
- Lee, D.C., Halliday, J.G., Fitton, J.G., Poli, G., 1994. Isotopic variations with distances and time in the volcanic islands of the Cameroon line: evidence for mantle plume origin. *Earth Planet. Sci. Lett.* 123, 119–139.
- Maca-Meyer, N., Carranza, S., Rando, J., Arnold, E., Cabrera, V., 2003. Status and relationships of the extinct giant canary island lizard *Gallotia galloti* (Reptilia: lacertidae) assessed using ancient mtDNA from its mummified remains. *Biol. J. Linn. Soc.* 80, 659–670.
- Measey, G.J., Vences, M., Drewes, R.C., Chiari, Y., Melo, M., Bourles, B., 2007. Freshwater paths across the ocean: molecular phylogeny of the frog *Ptychocheilichthys newtoni* gives insights into amphibian colonization of oceanic islands. *J. Biogeogr.* 34, 7–20.
- Meyers, J., Rosendahl, B., Harrison, C., Ding, Z., 1998. Deep-imaging seismic and gravity results from offshore Cameroon Volcanic Line, and speculation of African hotlines. *Tectonophysics* 284, 31–63.
- Mittleman, M.B., 1952. A generic synopsis of the lizards of the subfamily Lygosominae. *Smithson. Misc. Collect.* 117, 1–35.
- Myers, N., Mittmeier, R.A., Mittmeier, C.G., Da Fonseca, G.A., Kent, J., 2000. Biodiversity hotspots for conservation priorities. *Nature* 403, 853–858.
- Palumbi, S., Martin, A., Romano, S., McMillan, W., Stick, L., Grabowski, G., 1991. The single tools guide to PCR Marine Version 2. Honolulu, Hawaii.
- Perret, J.-L., 1973. Contribution à l'étude des *Panaspis* (Reptilia, Scincidae) d'Afrique occidentale avec la description de deux espèces nouvelles. *Rev. Suisse Zool.* 80, 595–630.
- Perret, J.-L., 1975. La différenciation dans le genre *Panaspis* Cope (Reptilia, Scincidae). *Bull. Soc. neuch. Sci. Nat.* 98, 5–16.
- Posada, D., Crandall, K.A., 1998. Modeltest: testing the model of DNA substitution. *Bioinformatics* 14, 817–818.
- Posada, D., Buckley, T.R., 2004. Model selection and model averaging in phylogenetics: advantages of the AIC and Bayesian approaches over likelihood ratio tests. *Syst. Biol.* 53, 793–808.
- Rambaut, A., Drummond, A., 2005. Tracer. A program for analysing results from Bayesian MCMC programs such as BEAST & MrBayes. Version 1.3. <<http://evolve.zoo.ox.ac.uk/software.html?id=tracer>>
- Rodríguez, F., Oliver, J.F., Marín, A., Medina, J.R., 1990. The generative stochastic model of nucleotide substitutions. *J. Theor. Biol.* 142, 485–501.
- Saint, K.M., Austin, C.C., Donnellan, S.C., Hutchinson, M.N., 1998. *C-mos*, a nuclear marker useful for squamate phylogenetic analysis. *Mol. Phylogenet. Evol.* 10, 259–263.
- Sambrook, J., Fritsch, E.F., Maniatis, T., 1989. *Molecular Cloning: A Laboratory Manual*, third ed. Cold Spring Harbour Press, New York.
- Schmitz, A., Ineich, I., Chirio, L., 2005. Molecular review of the genus *Panaspis* sensu lato (Reptilia: Scincidae) in Cameroon, with special reference to the status of the proposed subgenera. *Zootaxa* 863, 1–28.

- Simkin, T., Siebert, L., 1994. *Volcanoes of the World*. Geoscience Press, Tucson, Arizona.
- Simon, C., Franke, A., Martin, A., 1990. The polymerase chain reaction: DNA extraction and amplification. In: Hewitt, G., Johnston, A., Young, Y. (Eds.), *Molecular techniques in taxonomy*. NATO ASI Series, vol. H57. Springer Verlag, Berlin, pp. 329–357.
- Smith, M.A., 1937. A review of the genus *Lygosoma* (Scincidae: Reptilia) and its allies. *Rec. Indian Mus.* 39, 213–234.
- Swofford, D.L., 2002. PAUP*: Phylogenetic Analysis Using Parsimony (and other methods) 4.0.b10. Sinauer Associates Sunderland, Massachusetts, USA.
- Swofford, D.L., Olsen, G.J., Waddell, P.J., Hillis, D.M., 1996. Phylogenetic inference. In: Hillis, D.M., Moritz, C., Mable, B.K. (Eds.), *Mol. Syst.*, second ed. Sinauer Associates, Sunderland, MA.
- Thompson, J.D., Higgins, D.G., Gibson, T.J., 1994. Clustal W: improving the sensitivity of progressive multiple sequence alignment through sequence weighting, position specific gap penalties and weight matrix choice. *Nucleic Acids Res.* 22, 4673–4680.
- Thorpe, R.S., Leadbeater, D.L., Pook, C.E., 2005. Molecular clocks and geological dates: cytochrome *b* of *Anolis extremus* substantially contradicts dating of Barbados emergence. *Mol. Ecol.* 14, 2087–2096.
- Xia, X., Xie, Z., 2001. DAMBE: data analysis in molecular biology and evolution. *J. Hered.* 92, 371–373.
- Welch, K.G., 1982. *Herpetology of Africa: a checklist and bibliography of the orders Amphisbaenia, Sauria and Serpentes*. Robert E. Krieger Publishing Company Malabar, Florida.